

ULTRASONIC DISTANCE ESTIMATOR USER'S MANUAL

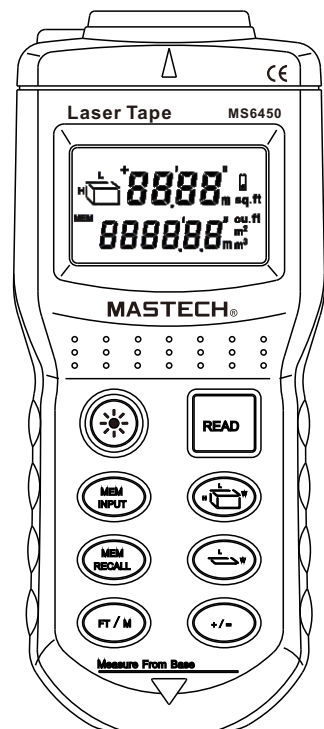

MASTECH®

This tool emits a laser beam, which, projects a visible spot on the target surface when the tool is used indoors.

Safety Instructions:

Failure to follow warnings may result in bodily injury.

Warnings:

Laser radiation emitted from tool class II laser product Max. Power Output <1mW, Wavelengths 630~670nm

DO NOT STARE INTO BEAM AVOID DIRECT EYE EXPOSURE THIS TOOL EMITS A LASER RADIATION IMPORTANT NOTE:

Read all instructions prior to operating this tool and DO NOT removes any labels from the tool.

CAUTION: Use of controls or performance of procedures other than those specified herein may result in hazardous radiation exposure.

DO NOT stares directly at the laser beam.

DO NOT projects the laser beam directly into the eyes of others.

DO NOT set up the tool at eye level or operates the tool on or near a reflective surface, as the laser beam could be projected into your eyes or the eyes of others.

Need To Know:

Inaccurate measurement may result from the following:

- When the battery runs out.
- When the measured distance is out of the specified range (0.6 to 15m or 2' to 50')
- When another ultrasonic source is nearby.
- When the unit is not held perpendicularly to the target. An error message "Err" will be displayed under the following conditions:

MASTECH®

- The calculation result exceeded the calculation range as specified.
The target surface does not provide good reflection for ultrasonic pulse (i.e. soft and irregular surface such as thick carpet, curtain or irregular wall paper etc).
- The distance measured is out of specified range (>15m/50').

Technical Specifications:

Recommended use:	Indoor
Measurement range:	0.6~15m (2'~50')
Accuracy:	±0.5%±1Digit
Resolutions:	0.01m (1')
Aperture angle:	approx. ±5 degrees
Laser Diode type:	Red laser diode 650nm.
Power supply:	9V block battery
Battery life:	10 hours of continuous dynamic measurement with alkaline battery.
Dimensions:	137X59X39mm
Weight:	approx. 150g (include battery)

Calculation range:

Length:	9999m
Area	99999m ²
Volume	99999m ³

Operation Environment:

Operating temperature:0°C to 40°C
Still air and hard target surface for accurate measurement.

MASTECH®

Important Note:

For long distance measuring (between 12m~15m), the relative humidity should be above 48% and target size of at least 3m by 3m.

Tool Components:

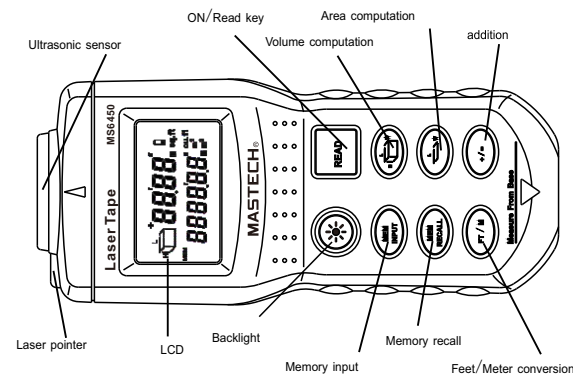

Battery Installation:

- Open battery compartment door on the back.
- Plug one 9 volt battery onto the battery connector.
- Close battery compartment door.

Important Note:

When battery is low, the low battery icon will be continuously displayed on the LCD.

MASTECH®

How To Use Your Laser Tape

Position and point the unit perpendicular to the target. The laser pointer will show where the tool is pointing and is only on while a reading is being

- taken.
- The target must be a hard regular surface unencumbered by objects/obstacles in the measurement field.
- For more accurate result, choose a target that is flat and large with hard surfaces.
- Put a piece of cardboard in front of the target if the measured target is small. Irregular or soft.
- This tool can not measure through glass even though the laser beam can pass through.

Caution: Do not stare into laser beam. Hold tool with beam above or below eye level.

LCD Graphics:

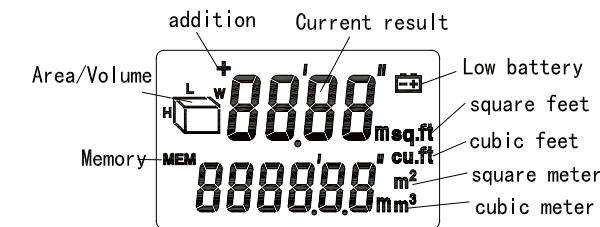

Laser Tape Operations:

- Select the measurement unit by pressing the “FT/M”
- Point to wall and get measured distance by pressing “Read”.
- For dynamic read, press and hold “Read” key to get measured distance displayed while the unit is moving.
- Each measurement erases the previous one.
- Measured distance is displayed on top of the LCD .
- Unit automatically turns itself off after 30 seconds of inactivity.

Important note:

Make sure to point the unit perpendicular to the target.

“+” Addition:

Adds measured lengths, areas and volumes together.

Important Note:

The addition between different modes (E.g. Length plus area) will result in error. “+” button is ignored and “Err” is shown on screen. Previous state is restored.

Addition (W/O Using Mem):

- Press “Read” for measurement.
- Press “+/-” to enter the addition mode. A “+” icon will appear on LCD.
- Press and hold “Read” again for second measurement.
- Press “+/-” again the sum is shown on the bottom.

Addition (Using Mem):

- Press “MEM INPUT” to save the desired measurement for the addition.
- Press “Read” for new measurement.
- After getting the new measurement, press “+/-” to enter the addition mode. A “+” icon will appear on LCD.

Press “MEM Recall” to recall previous

- measurement for the addition. The “MEM” icon will disappear and the stored memory will be automatically cleared.
- Press “+/-” again, the sum is shown on the bottom.

Area:

- Press “LW” to enter Area mode for calculation of a room area.
- “L” will blink showing which measurement you will be taking. Press “Read” to take “L” measurement that is displayed on upper portion of screen. (Step1)
- “W” will blink showing the next measurement to take. Press “Read” to take “W” measurement that is displayed on upper portion of screen. (Step2).
- Then the Area is automatically displayed on the lower portion of the screen.
- Pressing the “Read” key again will toggle back and forth between the “L” and “W” measurements.
- To start another Area mode, press “LW” key again.
- To leave the Area mode to make a single measurement, press and hold the “Read” key for about 2 seconds.

Addition Of Areas Under Area Mode:

- Press “MEM INPUT” to save the calculated area.
- Press “LW” to measure new area (Follow Step1&2 under the Area section).
- After getting the desired area, press “+/-” to enter the addition mode. A “+” icon would appear on LCD.
- Press “MEM RECALL” to recall the first calculated area for the addition. The “MEM” icon will disappear and the stored memory will be automatically cleared.
- Press “+/-” again, the sum of both areas is shown on bottom.

Important Note:

Before press and hold “READ” to leave the Area mode, the measurement of “L” and “W” must be completed first.

Volume:

- Press “LWH” to enter Volume mode for calculation of a room volume.
- “L” will blink showing which measurement you will be taking. Press “Read” to take “L” measurement that is displayed on upper portion of screen. (Step1)
- “W” will blink showing the next measurement to take. Press “Read” to take “W” measurement that is displayed on upper portion of screen. (Step2)
- “H” will blink showing the next measurement to take. Press “Read” to take “H” measurement that displayed on upper portion of screen. (Step3)
- Then the volume is automatically displayed on the lower portion of the screen.
- Pressing the “Read” key again will toggle back and forth between the “L”, “W” and “H” measurements.
- To start another volume mode, press “LWH” key again.
- To leave the volume mode to make a single measurement, press and hold the “Read” key for about 2 seconds.

Addition Of Volumes Under Volumemode:

- Press “MEM INPUT” to save to the calculated volume.
- Press “LWH” to measure new volume (Follow Step1 to 3 under the volume section).
- After getting the calculated volume, press “+/-” to enter the addition mode. A “+” icon would appear on LCD. Press “MEM RECALL” to recall the first calculated
- volume for the addition. The “MEM” icon will disappear and the stored memory will be automatically cleared.
- Press “+/-” again, the sum of both volumes is shown on bottom.

Important Note:

Before press and hold “Read” to leave the volume mode, the measurement of “L”, “W” and “H” must be completed first

Mem Input:

Store a length, area or volume into memory. And the “MEM” icon will appear.

Mem Recall:

Displays the last stored memory. And the “MEM” icon will be automatically cleared.

FT/M:

Change the measurement unit for length, area and volume from ft./in. to metric.

Care And Handling:

- The Laser Tape is a precision instrument which must be handled with care.
- Avoid shock, vibrations and extreme heat.
- Avoid dust and water, which may obstruct the lens, if needed, se a soft cloth or cotton swab and glass cleaner to clean the lens.
- Keep the laser tool dry and clean.
- Check battery regularly to avoid deterioration. Remove battery if the laser tool is to be stored for and extended period of time.

